



Two-Way Radios

User Guide



XT460 Display Model

Open Source Software Legal Notices:

This Motorola product contains Open Source Software. For information regarding licenses, acknowledgements, required copyright notices and other usage terms, refer to the documentation for this Motorola product at:

<http://businessonline.motorolasolutions.com>

Go to: Resource Center > Product Information > Manual > Accessories.

CONTENTS

Contents	1
Computer Software Copyrights	4
Safety	5
Batteries and Chargers Safety Information	6
Operational Safety Guidelines	7
Radio Overview	9
Parts Of The Radio	9
On/Off/Volume Knob	10
Channel Selector Knob	10
Accessory Connector	10
Model Label	10
Microphone	10
Antenna	10
LED Indicator	10
Front Buttons	10
Side Buttons	11
The Lithium-Ion (Li-Ion) Battery	11
Batteries and Chargers	13
Battery Features And Charging Options	13
About the Li-Ion Battery	13

Installing the Lithium-Ion (Li-Ion) Battery	14
Removing the Lithium-Ion (Li-Ion) Battery	14
Power Supply and Drop-in Tray Charger	15
Holster	16
Charging The Battery	16
Charging with the Drop-in Tray Single Unit Charger (SUC)	16
Drop-in Tray Charger LED Indicators	18
Battery Meter	19
Estimated Charging Time	20
Getting Started	22
Turning radio ON/OFF	22
Adjusting Volume	22
Reading The Display	22
Selecting a Channel	23
Talking and Monitoring	23
Receiving a Call	23
Signal Strength Indicator and Channel Busy Indicators	24
Talk Range	24

Radio LED Indicators	26	Programming Rx (Reception)	
Hands-Free Use/VOX	27	Frequencies	35
With Compatible VOX Accessories	27	Programming Rx (Reception) Codes	
Setting iVOX Sensitivity	27	(CTCSS/DPL)	35
Microphone Gain	28	Programming Scramble	36
Hands Free without Accessories		Scan	37
(iVOX)	28	Programming Scan List	38
Toggle Voice Prompt in User Mode	28	Editing Channel Alias Name	39
Power Up - Tone Mode	28	Nuisance Channel Delete	40
Reset to Factory Defaults	28	Customer Programming Software	
Keypad Beeps	29	(CPS)	40
Keypad Lock/Unlock	29	Time-Out Timer	41
Menu Options	29	Reverse Burst	41
Setting VOX /iVOX		Cloning Radios	42
Sensitivity – Menu	29	Cloning with a Multi-Unit	
Setting VOX /iVOX		Charger (MUC)	42
Sensitivity – CPS	30	CPS and Cloning Cables	
Microphone Gain Menu	30	(Optional Accessory)	44
Microphone Accessory Gain Level	31	Cloning Radio using the Radio	
Call Tones	32	to Radio (R2R) Cloning Cable	
Scan List Menu	33	(Optional Accessory)	45
Programming Features	34	Cloning using the Customer	
Advanced Configuration Mode	34	Programming Software (CPS)	47

Troubleshooting	48
Use and Care	52
Frequency and Code Charts	53
CTCSS and PL/DPL Codes	54
Motorola Limited Warranty	59
Accessories	61
Audio Accessories	61
Battery	61
Cables	61
Chargers	61
Carry Accessories	61

COMPUTER SOFTWARE COPYRIGHTS

The Motorola products described in this manual may include copyrighted Motorola computer programs stored in semiconductor memories or other media. Laws in the United States and other countries preserve for Motorola certain exclusive rights for copyrighted computer programs, including, but not limited to, the exclusive right to copy or reproduce in any form the copyrighted computer program. Accordingly, any copyrighted Motorola computer programs contained in the Motorola products described in this manual may not be copied, reproduced, modified, reverse-engineered, or distributed in any manner without the express written permission of Motorola.

Furthermore, the purchase of Motorola products shall not be deemed to grant either directly or by implication, estoppel, or otherwise, any license under the copyrights, patents or patent applications of Motorola, except for the normal non-exclusive license to use that arises by operation of law in the sale of a product.

SAFETY

PRODUCT SAFETY AND RF EXPOSURE COMPLIANCE



Caution

Before using this product, read the operating instructions and RF energy awareness information contained in the Product Safety and RF Exposure booklet enclosed with your radio.

ATTENTION!

This radio is restricted to occupational use only to satisfy FCC / ICNIRP RF energy exposure requirements.

For a list of Motorola-approved antennas, batteries and other accessories, visit the following website which lists approved accessories:

www.motorolasolutions.com/XTseries

BATTERIES AND CHARGERS SAFETY INFORMATION

This document contains important safety and operating instructions. Read these instructions carefully and save them for future reference.

Before using the battery charger, read all the instructions and cautionary markings on

- the charger,
 - the battery, and
 - the radio using the battery
1. To reduce risk of injury, charge only the rechargeable Motorola-authorized batteries. Other batteries may explode, causing personal injury and damage.
 2. Use of accessories not recommended by Motorola may result in risk of fire, electric shock, or injury.

3. To reduce risk of damage to the electric plug and cord, pull by the plug rather than the cord when disconnecting the charger.
4. An extension cord should not be used unless absolutely necessary. Use of an improper extension cord could result in risk of fire and electric shock. If an extension cord must be used, make sure that the cord size is 18AWG for lengths up to 100 feet (30.48 m), and 16AWG for lengths up to 150 feet (45.72 m).
5. To reduce risk of fire, electric shock, or injury, do not operate the charger if it has been broken or damaged in any way. Take it to a qualified Motorola service representative.
6. Do not disassemble the charger; it is not repairable and replacement parts are not available. Disassembly of the charger may result in risk of electrical shock or fire.
7. To reduce risk of electric shock, unplug the charger from the AC outlet before attempting any maintenance or cleaning.

OPERATIONAL SAFETY GUIDELINES

- Turn the radio OFF when charging battery.
- The charger is not suitable for outdoor use. Use only in dry locations/conditions.
- Connect charger only to an appropriately fused and wired supply of the correct voltage (as specified on the product).
- Disconnect charger from line voltage by removing main plug.
- The outlet to which this equipment is connected should be nearby and easily accessible.
- In equipment using fuses, replacements must comply with the type and rating specified in the equipment instructions.
- Maximum ambient temperature around the power supply equipment must not exceed 40°C (104°F).
- Power output from the power supply unit must not exceed the ratings stated on the product label

located at the bottom of the charger.

- Make sure that the cord is located where it will not be stepped on, tripped over, or subjected to water, damage, or stress.

Notes

RADIO OVERVIEW

PARTS OF THE RADIO

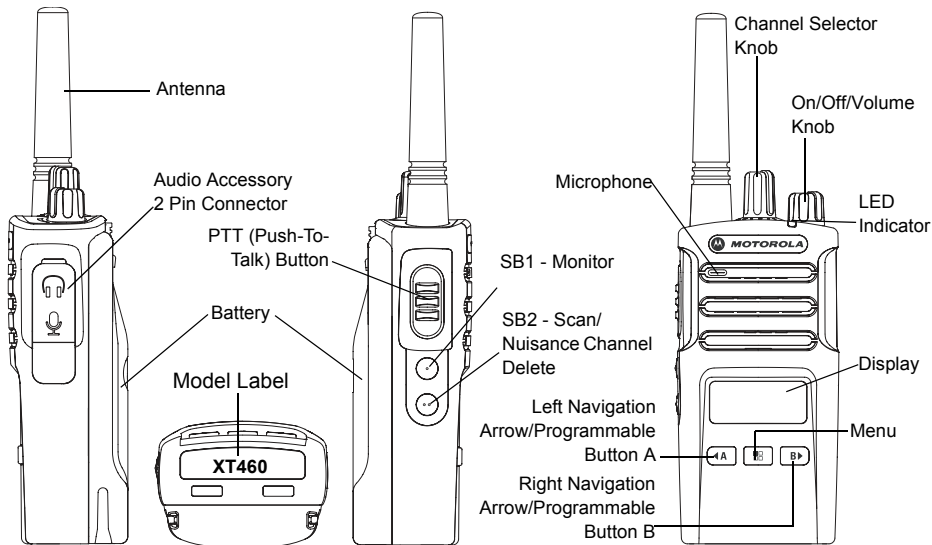

On/Off/Volume Knob

Used to turn the radio ON or OFF and to adjust the radio's volume.

Channel Selector Knob

Used to switch the radio to different channels.

Accessory Connector

Used to connect compatible audio accessories.

Model Label

Indicates the model of the radio.

Microphone

Speak clearly into the microphone when sending a message.

Antenna

For model **XT460**, the antenna is non-removable.

LED Indicator

Used to give battery status, power-up status, radio call information and scan status.

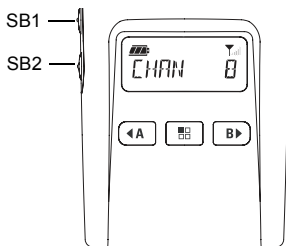
Front Buttons**(Menu) Button**

- Gives access to set up features like VOX/iVOX levels, etc. It also allows you to move through all the features while in Programming Mode.

**Programmable Button**



- Allows you to choose level or toggle options for features the Menu is on. Default set to generate current programmed call tone.

B▶

Programmable Button

Allows you to choose level or toggle options for features the Menu is on.

Default set to Backlight Mode.

Note: Buttons , , SB1 and SB2 are programmable. For example: Scramble, Scan/Nuisance Channel Delete, Monitor and Call Tones. To learn more about how to program these buttons, refer to “Customer Programming Software (CPS)” on page 40

Side Buttons

Push-to-Talk (PTT) Button

- Press and hold down this button to talk, release it to listen.

Side Button 1 (SB1)

- The Side Button 1 is a general button that can be configured by the Customer Programming Software - CPS. The SB1 default setting is ‘Monitor’.

Side Button 2 (SB2)

- The Side Button 2 is a general button that can be configured by the CPS. The SB2 default setting is ‘Scan/Nuisance Channel Delete’.

The Lithium-Ion (Li-Ion) Battery

XT Series comes with a Standard Capacity Li-Ion battery. Other batteries may be available. For more information, see “Battery Features And Charging Options” on page 13.

This User Guide covers the XT460 model from the XT Series radios. The radio's model is shown on the bottom of the radio and provides the following information:

Table 1: XT460 Radio Specifications

Model	Frequency Band	Transmit Power (Watts)	Number of Channels	Antenna
XT460	PMR446	0.5	16	Non-removable

BATTERIES AND CHARGERS

XT Series radios provide Lithium-Ion batteries that come in different capacities that defines the battery life.

BATTERY FEATURES AND CHARGING OPTIONS

About the Li-Ion Battery

The XT Series radio comes equipped with a rechargeable Li-Ion battery. This battery should be fully charged before initial use to ensure optimum capacity and performance.

Battery life is determined by several factors. Among the more critical are the regular overcharge of batteries and the average depth of discharge with each cycle. Typically, the greater the overcharge and the deeper the average discharge, the fewer cycles a battery will last. For example, a battery which is overcharged and discharged 100% several

times a day, lasts fewer cycles than a battery that receives less of an overcharge and is discharged to 50% per day. Further, a battery which receives minimal overcharging and averages only 25% discharge, lasts even longer.

Motorola batteries are designed specifically to be used with a Motorola charger and vice versa. Charging in non-Motorola equipment may lead to battery damage and void the battery warranty. The battery should be at about 77°F (25°C) (room temperature), whenever possible. Charging a cold battery (below 50° F [10°C]) may result in leakage of electrolyte and ultimately in failure of the battery. Charging a hot battery (above 95°F [35°C]) results in reduced discharge capacity, affecting the performance of the radio. Motorola rapid-rate battery chargers contain a temperature-sensing circuit to ensure that batteries are charged within the temperature limits stated above.

Installing the Lithium-Ion (Li-Ion) Battery

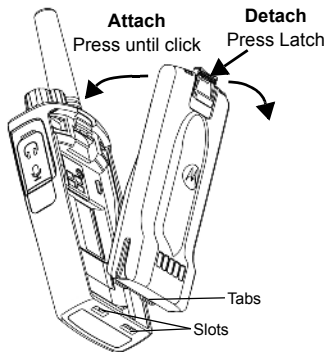

1. Turn OFF the radio.
2. With the Motorola logo side up on the battery pack, fit the tabs at the bottom of the battery into the slots at the bottom of the radio's body.
3. Press the top part of the battery towards the radio until a click is heard.

Note: To learn about the Li-Ion Battery Life features, refer to "About the Li-Ion Battery" on page 13

Removing the Lithium-Ion (Li-Ion) Battery

1. Turn OFF the radio.
2. Push down the battery latch and hold it while removing the battery.
3. Pull the battery away from the radio.

**Table 1: Li-Ion Battery Life with Tx Power
0.5 Watts**

Battery Type	Battery Save OFF	Battery Save ON
Standard	16 Hours	20 Hours
High Capacity	N/A	N/A

Power Supply and Drop-in Tray Charger

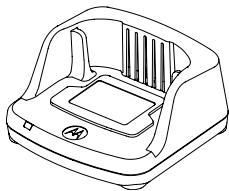

Drop-in Tray Charger

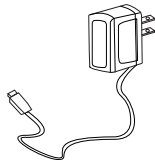

Power Supply

Your radio comes with one Drop-n Tray Charger and one Power Supply (also known as Transformer) and a set of adaptors.

Your Power Supply is capable of switching to suit any of the adaptors that comes with your radio package.

The Adaptor you install depends on the region you're located.

Once you have identified the Adaptor that matches your electrical outlet, proceed to install it as follows:

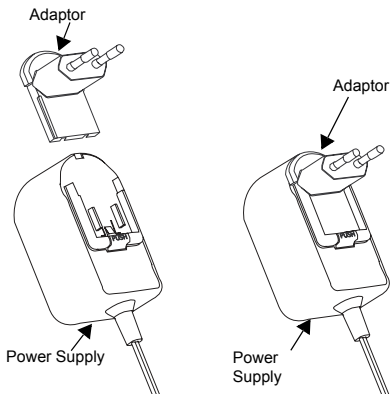

- Slide down the Adaptor grooves into the Power Supply until it snaps into place.
- Slide the Adaptor upward to remove.

Note: The adaptor shown in the pictures are for illustration purposes only. The adaptor you install may be different.

When acquiring additional Charger or Power Supply, make sure you have the similar Drop-in Tray Charger and Power Supply set.

Holster

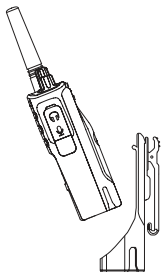

1. Insert the radio into the base of the holster at an angle. Press the radio against the back of the holster until the hooks on the holster are inserted in the top recesses of the battery.
2. To remove, using the top tab on the holster, detach the hooks of the holster from the top recesses of the battery. Slide the radio at an angle and remove from the holster.

CHARGING THE BATTERY

To charge the battery (with the radio attached), place it in a Motorola approved Drop-in Tray Single Unit Charger or Multi-Unit Charger.

Charging with the Drop-in Tray Single Unit Charger (SUC)

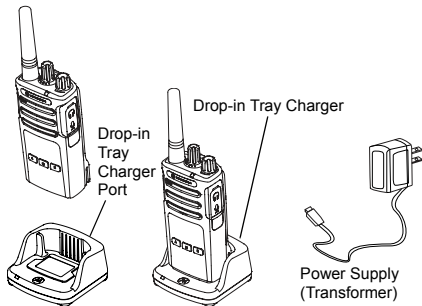

1. Place the Charger on a flat surface.
2. Insert the connector of the Power Supply into the port on the side of the Charger.
3. Plug the AC Adaptor into a power outlet.
4. Insert the radio into the Charger with the radio facing the front, as shown.

Note: When charging a battery attached to a radio, turn the radio OFF to ensure a full charge. See "Operational Safety Guidelines" on page 7 for more information.

Charging A Stand-Alone Battery

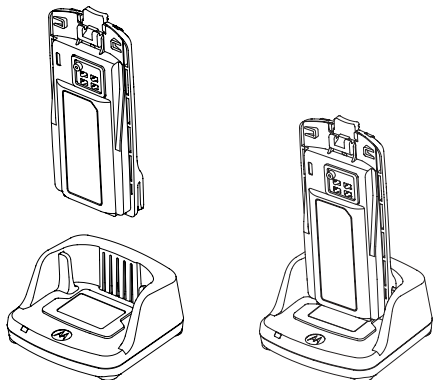









To charge only the battery - at step 4 on page 16, insert the battery into the tray, with the inside surface of the battery facing the front of the Drop-in Tray Single Unit Charger as shown above. Align the slots in the battery with the alignment ribs in the Drop-in Tray Single Unit Charger.

Table 2: Motorola Authorized Batteries

Part Number	Description
PMNN4434_R	Standard Li-Ion Battery
PMNN4453_R	High Capacity Li-Ion Battery

Drop-in Tray Charger LED Indicators

Table 3: Charger LED Indicator

Status	LED Indicator	Comments
Power On	Green for approximately 1 second 	
Charging	Steady Red 	
Charging Complete	Steady Green 	
Battery Fault (*)	Red Fast Flash 	
Waiting to Charge (**)	Amber Slow Flash 	
Battery Level Status	N/A	Battery empty
	Flash Red 1 Time 	Battery low
	Flash Amber 2 Times 	Battery medium
	Flash Green 3 Times 	Battery High

(*) Normally, re-positioning the battery pack will correct this issue.

(**) Battery temperature is too warm or too cold or wrong power voltage is being used.



If there is NO LED indication:

1. Check if the radio with battery, or the battery alone, is inserted correctly. (refer to step 4 of "Charging with the Drop-in Tray Single Unit Charger (SUC)" on page 16)
2. Ensure that the power supply cable is securely plugged into the charger socket using an appropriate AC outlet and there is power to the outlet.
3. Confirm that the battery being used with the radio is listed in Table 2.

Battery Meter

The battery meter located in the upper left corner of the radio display indicates how much battery power the radio has remaining.

Table 4: XT460 Battery Meter

Battery Type	Battery Meter		
	3 Bars	2 Bars	1 Bar
Li-Ion			
	100 – 70%	70 – 30%	35 – 0% (≤ 10% when blinking)

Estimated Charging Time

The following table provides the estimated charging time of the battery. For more information, see “Battery” on page 61.

Table 5: Battery Estimated Charging Time

Charging Solutions	Estimated Charging Time	
	Standard Battery	High Capacity Battery
Standard	≤ 4.5 Hours	N/A
Rapid	≤ 2.5 Hours	N/A

Charging a Radio and Battery using a Multi-Unit Charger - MUC (Optional Accessory)

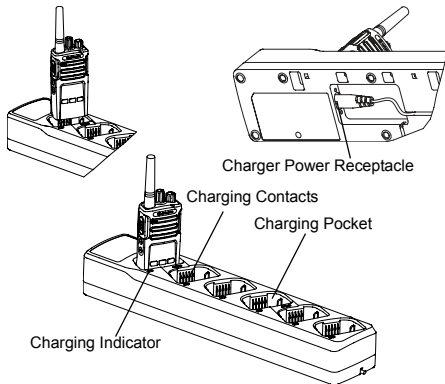

The Multi-Unit Charger (MUC) allows drop-in charging of up to 6 radios or batteries. Batteries can be charged with the radios or removed and placed in the MUC separately. Each of the 6 charging pockets can hold a radio (with or without the Holster) or battery, but not both.

1. Place the MUC on a flat surface.
2. Insert the power cord plug into the MUC's dual pin connector at the bottom of the MUC.
3. Plug the power cord into an AC outlet.
4. Turn the radio OFF.
5. Insert the radio or battery into the charging pocket with the radio or battery facing away from the contacts.

Note:

- This MUC clones up to 2 radios (2 Source radios and 2 Target radios). Refer to "Cloning with a Multi-Unit Charger (MUC)" on page 42 for more information.
- More information on the MUC's operation is available in the Instruction Sheets provided with the MUC. For more information on the parts and their part numbers, refer to "Accessories" on page 61.
- Refer to Table 3 on page 18 for more information on the MUC's LED Indicators.

GETTING STARTED

For the following explanations, refer to “Parts Of The Radio” on page 9.

TURNING RADIO ON/OFF

To turn ON the radio, rotate the On/Off/Volume Knob clockwise. The radio plays one of the following:

- Power up tone and channel number announcement, or
- Battery level and channel number announcements, or
- Silent (Audible tones disabled)

The LED blinks red briefly.

To turn the radio OFF, rotate the On/Off/Volume Knob counterclockwise until you hear a ‘click’ and the radio LED Indicator turns OFF.

ADJUSTING VOLUME

Turn the On/Off/Volume Knob clockwise to increase the volume, or counterclockwise to decrease the volume.

Note: Do not hold the radio too close to the ear when the volume is high or when adjusting the volume

READING THE DISPLAY

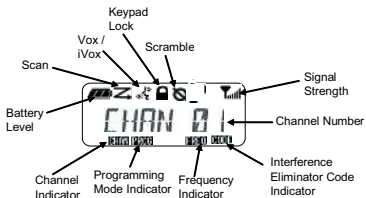

Note: The radio display shown here is for icon location only. Each radio display may appear different (channel and code) based on the pre-programmed radio defaults and features available in the model or region. Pressing any button, except the PTT button, will turn on the backlight.

SELECTING A CHANNEL

To select a channel, turn the Channel Selector Knob until you reach the desired channel. An audible voice indicates the selected channel.

Each channel has its own Frequency, Interference Eliminator Code and Scan Settings.

TALKING AND MONITORING

It is important to monitor for traffic before transmitting to avoid 'talking over' someone who is already transmitting

To monitor, long press and hold the SB1(*) button to access channel traffic. If no activity is present, you will hear 'static'. To release, press SB1 again. Once channel traffic has cleared, proceed with your call by pressing the PTT button. When transmitting, the LED Indicator stays solid red.

Notes:

- To listen to all activity on a current channel, short press the SB1 to set the CTCSS/DPL code to 0. This feature is called 'CTCSS/DPL Defeat (Squelch set to SILENT)'.
- (*) This assumes SB1 is not being programmed for a different mode.

RECEIVING A CALL

1. Select a channel by pressing the rotating the Channel Selector Knob until you reach the desired channel.
2. Make sure the PTT button is released and listen for voice activity.
3. The LED Indicator stays solid red when the radio is receiving a call.
4. To respond, hold the radio vertically 1 to 2 inches (2.5 to 5cm) from mouth. Press the PTT button to talk; release it to listen.

Note: The LED stays solid red when the radio is receiving or transmitting.

Signal Strength Indicator and Channel Busy Indicators

When there is activity on a frequency, the radio blinks the Signal Strength Indicator icon  (without the bars) and the radio LED stays solid orange. The radio Signal Strength Indicator icon can change from 1 (weakest) to 6 (strongest) depending on the radio reception coverage. When the radio is in receiving mode, the radio displays the Signal Strength Indicator icon with bars.

Note: Obstacles blocking the signal path affects the strength of incoming signal.

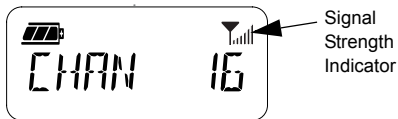

TALK RANGE

XT Series radios have been designed to maximize performance and improve transmission range in the field. It is recommended that you do not use the radios closer than 1.5 meters apart, to avoid interference. XT460 coverage is 16.250 square meters, 13 floors and 9 km in flat areas.

Talk range depends on the terrain. It will be affected by concrete structures, heavy foliage and by operating radios indoors or in vehicles. Optimal range occurs in flat, open areas with up to 9 kilometers of coverage. Medium range occurs when buildings and trees are in the way. Minimal range occurs when dense foliage and mountains obstruct the communication path.

To establish a proper two-way communication, the Channel, Frequency and Interference Eliminator Codes must be the same on both radios. This depends on the stored profile that has been pre-programmed on the radio:

1. **Channel:** Current channel that the radio is using, depending upon radio model.
2. **Frequency:** The frequency the radio uses to transmit/receive.
3. **Interference Eliminator Code:** These codes help minimize interference by providing a choice of code combinations.
4. **Scramble Code:** Codes that make the transmissions sound garbled to anyone listening who is not set to that specific code.

For details of how to set up frequencies and CTCSS/DPL codes in the channels, refer to “Advanced Configuration Mode” on page 34.

RADIO LED INDICATORS

RADIO STATUS	LED INDICATION
Channel Alias Edit	Red Heartbeat
Channel Busy	Solid Orange
Cloning Mode	Double Orange Heartbeats
Cloning In Progress	Solid Orange
Fatal Error at Power up	One Green Blink, One Orange Blink, One Green Blink, then repeat for 4 seconds
Low Battery	Orange Heartbeat
Low Battery Shutdown	Fast Orange Heartbeat
Monitor	LED is OFF
Power-Up	Solid Red for 2 seconds
'Idle' Programming Mode / Channel Mode	Green Heartbeat
Scan Mode	Fast Red Heartbeat
Transmit (Tx)/Receive (RX)	Solid Red
VOX/iVOX Mode	Double Red Heartbeats

HANDS-FREE USE/VOX

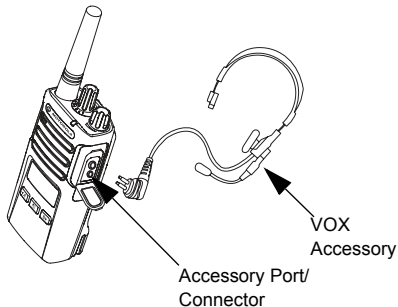

Motorola XT Series radios can operate hands-free (VOX) when used with compatible VOX accessories.

With Compatible VOX Accessories

The default factory setting for VOX sensitivity level is Medium ('2'). Before using VOX, use the Customer Programming Software (CPS) to set the VOX sensitivity level to a different level from '2'. Then, perform the following steps:

1. Turn the radio OFF.
2. Open accessory cover.
3. Insert the audio accessory's plug firmly into accessory port.
4. Turn radio ON. The LED Indicator will blink double red
5. Lower radio volume BEFORE placing accessory near ear.
6. To transmit, speak into accessory microphone and to receive, stop talking.
7. VOX can be temporarily disabled by pressing the PTT button or by removing the audio accessory.

VOX can also be activated using the  (Menu) button without using the CPS.

Note: To order accessories, contact your Motorola point of purchase

Setting iVOX Sensitivity

The sensitivity of the radio's accessory or microphone can be adjusted to suit different operating environments. iVOX sensitivity can be programmed via the CPS or the  (Menu) button.

Default value is “3”. iVOX can be set to any value as listed below:

- 1 = High audio input levels trigger the Tx
- 2 = Medium sensitivity
- 3 = Low audio input levels trigger the Tx

Microphone Gain

The sensitivity of the microphone can be adjusted to fit different users or operating environments.

This feature can be adjusted using the  (Menu) button or the CPS. Microphone default setting is set to level 2 (medium gain).

Hands Free without Accessories (iVOX)

- Press the PTT button while turning ON the radio to enable iVOX. The icon  blinks.
- iVOX can be temporarily disabled by pressing the PTT button.
- A short press of the PTT Button re-enables iVOX.

Note:

- There is a short delay between the time when you start talking and when the radio transmits.
- For more information on setting VOX/iVOX sensitivity, refer to “Setting VOX /iVOX Sensitivity – Menu” on page 29.

Toggle Voice Prompt in User Mode

Short press the SB1 Button while turning ON the radio to enable/disable the Voice Prompt in User Mode. (Default is set to ON).

Power Up - Tone Mode

To enable/disable power up tone mode, press SB1 and SB2 buttons simultaneously for 2-3 seconds while powering up the radio until you hear a quick series of beeps and the power up voice announcement programmed.

Reset to Factory Defaults

Reset to Factory Defaults will set back all radio features to the original factory default settings. To do so, press PTT, SB2 and SB1 simultaneously while turning ON the radio until you hear a high tone chirp.

Keypad Beeps

To enable/disable Keypad Beeps, short press the SB2 button while turning ON the radio until you hear 'chirp' tone.



Keypad Lock/Unlock

You can lock the keypad to avoid accidentally changing your radio settings. To lock the radio keypad, press and hold the  (Menu) button for 4 seconds.

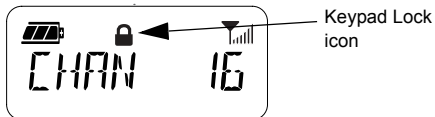
Note: The PTT Button and Programmable Button A (if Call Tone feature has been assigned) cannot be locked using this feature.



MENU OPTIONS

To access the radio MENU, short press the  (Menu) button. The radio displays the feature options. For each options, use the  and  buttons to navigate. After selecting your desired option settings, you can:

- press  (Menu) button to save and go to the next option, or
- long press the PTT button to save and exit, or
- turn OFF the radio to exit without saving the changes.

The MENU mode times out automatically if there is no activity detected for more than 10 seconds.

Setting VOX /iVOX Sensitivity – Menu

The VOX/iVOX sensitivity settings can be adjusted via the MENU as well as the CPS. To modify via the MENU, make sure you have enabled VOX or iVOX. (Refer to “Hands-Free Use/VOX” on page 27 or “Hands Free without

Accessories (iVOX)” on page 28 for more information). Once VOX/iVOX is enabled, short press the  (Menu) button.

If iVOX is enabled when you press the  (Menu) button, the radio displays the following:



If VOX is enabled (with accessory connected to the radio) when you press the  (Menu) button, the radio displays the following:



Setting VOX /iVOX Sensitivity – CPS

The sensitivity of the radio's accessory or microphone can be adjusted during VOX/iVOX operation to suit different operation environments. VOX/iVOX sensitivity can be programmed via the CPS.

Microphone Gain Menu

The sensitivity of the microphone can be adjusted to fit different users or operating environments.

Press the  (Menu) button until the radio displays the solid letters 'IMIC', VOX icon and blinks the current microphone gain level as follows:



Press the  (A) and  (B) buttons to toggle through the Microphone Gain settings:



- 1 = Low gain
- 2 = Medium gain
- 3 = High gain

Once you have selected the desired Microphone Gain Level, press the  (Menu) button to save and proceed to the next step, or turn OFF the radio to exit without saving changes. Microphone gain can also be configured using CPS.

Microphone Accessory Gain Level

The Microphone Gain Level for the accessory can be configured in the Microphone Accessory Gain Menu. Press the  (Menu) button until the radio displays the solid letters “MIC”, VOX icon and blinks the current radio accessory Microphone Gain as follows:



Press the  and  buttons to toggle through the Accessory Microphone Gain settings and select the desired Microphone Accessory Gain Level

- 1 = Low gain
- 2 = Medium gain
- 3 = High gain

Once you have selected the desired Microphone Accessory Gain Level, press the  (Menu) button to save and proceed to the next step, or turn OFF the radio to exit without saving changes. Microphone Accessory Gain Level can also be configured using CPS.

Note: If VOX and iVOX are enabled, the Mic or iMic cannot be configured in User Mode for XT460 as VOX and iVOX defaults to high microphone gain.



Call Tones

Call Tones feature allows you to transmit an audible tone to other radios on the same channel to alert them that you are about to talk or to alert them without speaking.

In 'Call Tone Selection Mode' you can configure the type of call tone for the radio. The settings available are dependent on the maximum number of call tones your radio supports.

To program Call Tones, press the  (Menu) button until the radio displays the solid letters "TONE" and blinks the current radio Call Tone as follows:



Press the  and  buttons to toggle through the Call Tones settings and select the



desired call tone value (0,1,2 or 3). Each time you select a different value, your radio sounds the selected call tone (except for value '0').

Once you have selected the desired call tone, press the  (Menu) button to save and proceed to the next step, or turn OFF the radio to exit without saving changes. Call Tones can also be configured using CPS.

Scan List Menu

You can enable the Channel Scanning Feature for a specific channel frequency for the radio in Scan List Menu. To enter the Scan Menu, press the  (Menu) button until the radio displays the channel number, the **CHAN** icon and blinks the current setting ('YES' or 'NO') as follows:



Press the  and  buttons to set SCAN to enable ('YES') or disable ('NO'). Press SB1 or SB2 button to cycle through all the channels. Once you have selected the scan setting, press the  (Menu) button to save and proceed to the next step, or turn OFF the radio to exit without saving changes. Scan List Menu can also be configured using CPS.

PROGRAMMING FEATURES

To easily program all the features in your radio, it is recommended to use the Customer Programming Software (CPS) and the programming cable.

CPS software download is available for free at www.motorolasolutions.com/XTSeries.

ADVANCED CONFIGURATION MODE

To enter 'Programming Mode', press and hold the PTT Button and the SB1 Button simultaneously for 3 seconds, while turning ON the radio. An audible voice announces the Channel Number, indicating the radio has entered 'Programming Mode'. The radio LED blinks a green heartbeat.

When the radio is set to 'Programming Mode', the **PROG** icon displays and the current channel aliasing name blinks to indicate that you can rotate the Channel Selector Knob to select the channel you want to program.

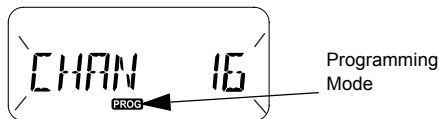

In 'Programming Mode', the radio is capable of setting values for each channel by toggling between the different programming modes available:

- Frequencies,
- CTCSS/DPL Codes (Interference Eliminator Code),
- Scramble, and
- Scan.
- To move along the different 'Programming Selection Mode' without saving changes, short press the PTT Button or  (Menu) Button.
- To save changes, long press the PTT Button. The radio returns to 'Idle' Programming Mode.
- When in 'Idle' Programming Mode, long press the PTT button to exit the 'Programming Mode'.
- Whenever you wrap around to the beginning of

the 'Programming Mode' options, the radio automatically saves all changes made, even if you turn OFF the radio.



- Exit the 'Programming Mode' without saving changes (as long as you have not wrapped around to the beginning of the 'Programming Mode' options) by turning OFF the radio.

PROGRAMMING RX (RECEPTION) FREQUENCIES

Once you have chosen the channel you want to program, short press the PTT button or  (Menu) button to scroll through the options until you reach 'Frequency Programming Mode'.

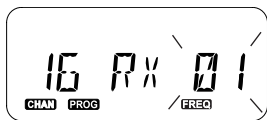
The radio display shows the frequency code as follows:





To program the desired frequency, use the  and  buttons to navigate to the frequency code value you need. Long press the PTT button to exit and save, or short press the PTT button to move to the next programming feature without saving.

PROGRAMMING RX (RECEPTION) CODES (CTCSS/DPL)

Once you have chosen the channel you want to program, short press the PTT button or  (Menu) button to scroll through the options until you reach the 'Code Programming Mode'.

The radio display shows the CTCSS/DPL code as follows:





To program the desired code, use the  and  buttons until you get the CTCSS/DPL code

value you want to set up. Long press the PTT button to exit and save, or short press the PTT button to move to the next programming feature without saving.



PROGRAMMING SCRAMBLE

The scramble feature makes your transmissions sound garbled to anyone listening without the same scramble code. It does not guarantee confidentiality, but it adds an extra layer of privacy. Scramble mode is by default set to 'OFF'.

Once you have entered 'Programming Mode' and selected the channel in which you want to enable Scramble () , scroll up or down through the programming modes by short pressing the PTT button or  (Menu) button until the radio reaches the Scramble Programming Mode.

The radio display shows the Scramble settings as follows:



The current scramble value blinks. You can select the desired scramble value (0,1,2,3 or 4) by pressing the  and  buttons. Long press the PTT button to exit and save, or short press the PTT button to move to the next programming feature without saving.

Note: Scramble is disabled when the value is set to '0'.

SCAN

Scan allows you to monitor other channels to detect conversations. When the radio detects a transmission, it stops scanning and goes to the active channel. This allows you to listen and talk to people in that channel without having to change channel manually. If there is talking going on Channel 2 during this time, the radio stays on Channel 1 and you will not hear Channel 2. After talking has stopped in Channel 1, the radio waits for 5 seconds before resuming scan again.

- To start scanning, press the SB1 or SB2 button (programmed for scan). When the radio detects channel activity, it stops on that channel until activity on that channel ends. You can talk to the person(s) transmitting without having to switch channels by pressing the PTT button.

Note: Scan has to be programmed either to SB1 or SB2 button via CPS. SB2 is by default Scan/Nuisance Channel delete button. If Auto-Scan has been enabled for a particular

channel, do not press SB1 or SB2 (programmed for scan) to start scanning, as the radio does it automatically.

- To stop scanning, short press the SB1 or SB2 button (programmed for scan) again.
- By pressing the PTT button while the radio is scanning, the radio will transmit on the channel which was previously selected before Scan is activated. If no transmission occurs within 5 seconds, scanning resumes.
- If you want to scan a channel without the Interference Eliminator Codes (CTCSS/DPL), set the code settings for the channels to '0' in the CTCSS/DPL Programming Selection Mode.

Note: Whenever the radio is set to Scan, the LED Indicator blinks a Red Heartbeat.



PROGRAMMING SCAN LIST

You can enable or disable the Channel Scanning feature for each channel in your radio. To do so, enter the 'Programming Mode' and select the channel you want to program. Scroll through the programming modes by short pressing the PTT button or  (Menu) button until you reach the 'Scan Programming Mode'.

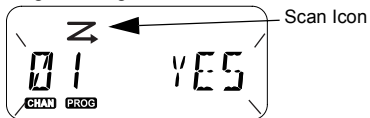
The radio display shows the Scan Programming Mode as follows:



Both the channel number and current scan setting (YES = Enable or NO = Disable) blinks on the display, indicating you can choose your setting. To set the channel number, rotate the Channel Selector Knob until you reach the desired channel number.

To enable ('YES') or disable ('NO') the scan feature, press the  and  buttons. To configure the channel number, use the SB1 and SB2 buttons. Once you have set the values you need, long press the PTT button to exit and save, or short press the PTT button to move to the next programming feature without saving.

Note: If the Maximum Channel (MAX CHAN) setting in the radio is set to '1', the Scan Programming option is disabled and will not show on the radio display.

Editing Channel Alias Name



To edit a Channel Alias Name, turn ON the radio and press and hold the PTT button simultaneously with the  button for 3 seconds. The radio generate a special beep upon entering the 'Channel Alias Mode'.

The radio display shows the current channel alias name and channel number blinking as follows:



Choose the channel number you want to edit by rotating the Channel Selector Knob. Once you have selected the channel number, short

press the PTT button or  (Menu) button to start editing the channel alias name.

- The character to be changed starts blinking. If it's a blank character, a cursor starts blinking.
- To change character, press the  and  buttons until the desired character is reached. To move to next character on the right, press the  (Menu) button. The character sequence is [A-Z], " " (Blank Space), [0-9] and Special Characters. No lower case is allowed.

Long press the PTT button to save and go back to the 'Channel Alias Mode' to choose other channel to edit the alias name or turn OFF the radio to exit without saving the changes.

Note: If the channel alias name is left blank, long pressing the PTT button does not save or leave the alias name.

NUISANCE CHANNEL DELETE

Nuisance Channel Delete allows you to temporarily remove channels from the Scan List. This feature is useful when irrelevant conversations on a 'nuisance' channel ties up the radio's scanning feature.

To delete a channel from the Scan List:

- Start Scan mode by short pressing the SB2(*) button.
- Wait until the radio stops receiving on the channel you wish to eliminate. Long press the SB2 button to delete it. You cannot delete the channel with scan enabled (home channel).
- The channel will not be scanned again until you exit the Scan mode by short pressing the SB2 button again or by turning OFF the radio and back ON.

Note: (*) This assumes the SB2 button is not programmed for a different mode.

CUSTOMER PROGRAMMING SOFTWARE (CPS)

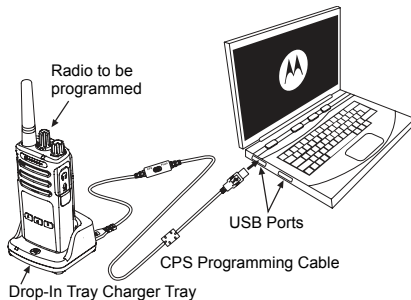

Figure 1: Setting up the radio to the CPS

The easiest way to program or change features in your radio is by using the Customer Programming Software (CPS) and the CPS Programming Cable(*). CPS Software is available for free as web based downloadable software at:

www.motorolasolutions.com/XTseries

To program, connect the XT Series radio via the Drop-in Charger Tray and CPS Programming Cable as shown in **Figure 1 on page 40**. Toggle the cable switch of the CPS Programming Cable to '**CPS Mode**'.

CPS allows you to program frequencies, PL/DPL Codes as well as other features such as: **Time-out Timer, Scan List, Call Tones, Scramble, Reverse Burst**, etc. CPS is a very useful tool as it can also lock the Front-Panel Radio Programming or restrict any specific radio feature to be changed (to avoid accidentally erasing the preset radio values). It also provides security by giving the option to set up a password for profile radio's management. For more information, refer to Features Summary Chart Section at the end of the User Guide.

Note: (*) CPS Programming Cable P/N# HKKN4027_ is an accessory sold separately. Please contact your Motorola point of purchase for more information.

Time-Out Timer

Transmissions can be terminated when the PTT button is pressed by setting up a Time-Out Timer.

Reverse Burst

Reverse Burst eliminates unwanted noise (squelch tail) during loss of carrier detection. You can select values of either 180 or 240 to be compatible with other radios.

- The features described in previous pages are just some of the features CPS has. CPS offers more capabilities. For more information refer to the HELP file in the CPS.
- Some of the features available with the CPS software may vary depending on the radio model.

CLONING RADIOS

You can clone XT Series radio profiles from one Source radio to a Target radio by using any one of these 3 methods:

- Using a Multi Unit Charger (MUC- optional accessory),
- Using two Single Unit Chargers (SUC) and a Radio-to-Radio cloning cable (optional accessory),
- the CPS (free software download)

Cloning with a Multi-Unit Charger (MUC)

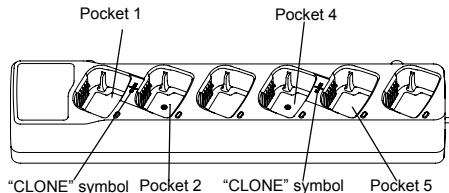

To clone radios using the MUC, there must be at least two radios:

- a Source radio (radio which profiles will be cloned or copied from) and
- a Target radio (the radio which profile will be cloned from the source radio.)

The Source radio has to be in Pocket 1 or 4 while the Target radio has to be in Pocket 2 or 5, matching in the MUCs pockets by pairs as follows:

- 1 and 2 or,
- 4 and 5.

When cloning, the MUC does not need to be plugged into a power source, but ALL radios require charged batteries.

1. Turn ON the Target radio and place it into one of the MUC Target Pockets
2. Power the Source radio following the sequence below:
 - Long press the PTT button and SB2

simultaneously while turning the radio ON.

- Wait for 3 seconds before releasing the buttons until the audible tone “Cloning” is heard.
3. Place the Source radio in the source pocket that pairs with the target pocket you chose in step 1. Press and release the SB1 button.
 4. After cloning is completed, the Source radio will announce either “successful” (cloning is successful) or “fail” (cloning has failed). If the Source radio is a display model, it will either show ‘Pass’ or ‘Fail’ on the display (a tone will be heard within 5 seconds).
 5. Once you have completed the cloning process, turn the radios OFF and ON to exit the ‘cloning’ mode.

Further details on how to clone radios are explained in the Instructions Sheet provided with the MUC.

When ordering the MUC, refer to P/N# PMLN6384_.

Notes:

- If cloning fails, refer to “What To Do If Cloning Fails” on page 46.
- Paired Target radios and Source radios must be of the same band type in order for the cloning to run successfully.
- MUC pockets numbers should be read from left to right with the Motorola logo facing front.

CPS and Cloning Cables (Optional Accessory)

- Both **CPS** and **Cloning Cables** are made to work either with XT Series radios or XTNi Series radios. Cloning cable supports a mix of XT and XTNi series radios.
- **CPS** cable programs XT series radios. Make sure the cable switch is in “Flash” or “CPS” position. To program a XTNi radio with the CPS cable, make sure the cable switch is in “CPS” position and the USB converter provided in the CPS cable kit is attached to the cable.
- **Cloning** cable allows you to clone:
 - XT Series radios. Make sure the switch is in “Cloning” or “Legacy” position.
 - XTNi Series radios. Make sure the switch is in “Legacy” position with one USB converter on each end of the cloning cable.
 - XT Series and XTNi Series radios. Make sure the switch is in “Legacy” position and use a USB converter to the XTNi Single-Unit Charger. The Cloning Cable Kit provides 1 USB converter.

CPS Cable

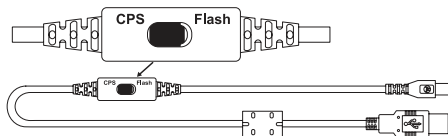

Cloning Cable

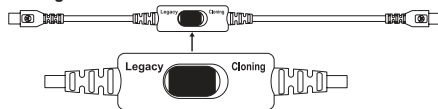

USB Converter

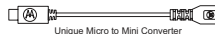

Cloning Radio using the Radio to Radio (R2R) Cloning Cable (Optional Accessory)

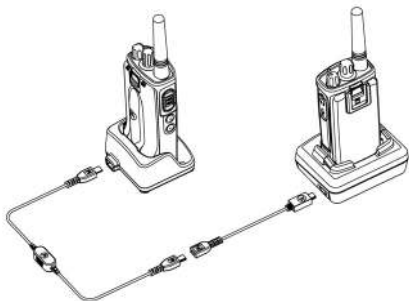

Operating Instructions

1. Before starting the cloning process, make sure you have:
 - A fully charged battery on each of the radios.
 - Two Single-Unit Chargers (SUC), or 2 SUC for cloning RM Series radios, or 1 SUC for XT Series radio and 1 SUC for XTNi Series radio.
 - Turn OFF the radios and,
 2. Unplug any cables (power supply or USB cables) from the SUCs.
 3. Plug one side of the cloning cable mini USB connector to the first SUC and the other end to the second SUC.
- Note:** During the cloning process, no power is being applied to the SUC. The batteries will not be charged. Only data communication is being established between the two radios.
4. Turn ON the Target Radio and place it into one of the SUCs.
 5. For the Source Radio, power ON the radio with the following sequence:
 - Long press the PTT button and the SB2 button simultaneously while turning the radio ON.
 - Wait 3 seconds before releasing the buttons and you hear a distinctive audible tone saying the word “Cloning”.
 6. Place the Source Radio in its SUC. Press and release the SB1 button.
 7. When the cloning is completed, the Source Radio audible voice will announce either

“successful” (cloning is successful) or “fail” (cloning process has failed). If the Source Radio is a display model radio, it will either show ‘Pass’ or ‘Fail’ on the display (a tone will be heard within 5 seconds).

8. Once the cloning process is completed, turn the Radios OFF and ON again to exit “Clone” mode.

What To Do If Cloning Fails

The radio audible voice will announce “Fail” indicating that the cloning process has failed. In the event that the cloning fails, perform each of the following steps before attempting to start cloning process again:

1. Ensure that the batteries on both radios are fully charged.
2. Check the cloning cable connection on both SUCs.
3. Ensure that the battery is engaged properly on the radio.

4. Ensure that there is no debris in the charging tray or on the radio contacts.
5. Ensure that the Target radio is turned ON.
6. Ensure that the Source radio is in cloning mode.
7. Ensure that the two radios are both from the same frequency band, same region and have the same transmission power.

Note: This cloning cable is designed to operate only with compatible Motorola SUC RLN6175 and PMLN6394.

When ordering Cloning Cable, please refer to P/N# HKKN4028_. For more information about the accessories, refer to “Accessories” on page 61.

Cloning using the Customer Programming Software (CPS)

When cloning using this method, you need the CPS software, a Drop-In Tray Charger and the CPS Programming Cable.

To order the CPS Programming Cable, please refer to P/N# HKKN4028_.

Information on how to clone using the CPS is available either in:

- the CPS Help File --> Content and Index --> Cloning Radios, or
- in the CPS Programming Cable Accessory Leaflet.

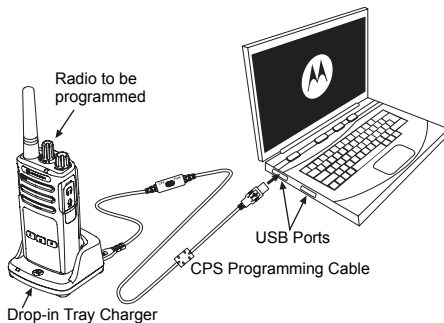

TROUBLESHOOTING

<i>Symptom</i>	<i>Try This...</i>
No Power	Recharge or replace the Li-Ion battery. Extreme operating temperatures may affect battery life. Refer to "About the Li-Ion Battery" on page 13
Hearing other noises or conversation on a channel	Confirm Interference Eliminator Code is set. Frequency or Interference Eliminator Code may be in use. Change settings: either change frequencies or codes on all radios. Make sure radio is at the right frequency and code when transmitting. Refer to "Talking and Monitoring" on page 23
Message Scrambled	Scramble Code might be ON, and/or setting does not match the other radios' settings.
Audio quality not good enough	Radio settings might not be matching up correctly. Double check frequencies, codes and bandwidths to make sure they are identical in all radios

Symptom	Try This...
Limited talk range	<p>Steel and/or concrete structures, heavy foliage, buildings or vehicles decrease range. Check for clear line of sight to improve transmission.</p> <p>Wearing radio close to body such as in a pocket or on a belt decreases range. Change location of radio. To increase range and coverage, you can reduce obstructions or increase power. UHF radios provides greater coverage in industrial and commercial buildings. Increasing power provides greater signal range and increased penetration through obstructions.</p> <p>Refer to “Talking and Monitoring” on page 23</p>
Message not transmitted or received	<p>Make sure the PTT button is completely pressed when transmitting. Confirm that the radios have the same Channel, Frequency, Interference Eliminator Code and Scramble Code settings. Refer to “Talking and Monitoring” on page 23 for further information.</p> <p>Recharge, replace and/or reposition batteries. Refer to “About the Li-Ion Battery” on page 13.</p> <p>Obstructions and operating indoors, or in vehicles, may interfere. Change location. Refer to “Talking and Monitoring” on page 23.</p> <p>Verify that the radio is not in Scan. Refer to “Scan” on page 37 and “Nuisance Channel Delete” on page 40.</p>

<i>Symptom</i>	<i>Try This...</i>
Heavy static or interference	Radios are too close; they must be at least five feet apart. Radios are too far apart or obstacles are interfering with transmission. Refer to “Talking and Monitoring” on page 23.
Low batteries	Recharge or replace Li-Ion battery. Extreme operating temperatures affect battery life. Refer to “About the Li-Ion Battery” on page 13.
Drop-in Charger LED light does not blink	Check that the radio/battery is properly inserted and check the battery/charger contacts to ensure that they are clean and charging pin is inserted correctly. Refer to “Charging The Battery” on page 16, “Drop-in Tray Charger LED Indicators” on page 18 and “Installing the Lithium-Ion (Li-Ion) Battery” on page 14.
Low battery indicator is blinking although new batteries are inserted	Refer to “Installing the Lithium-Ion (Li-Ion) Battery” on page 14, and “About the Li-Ion Battery” on page 13.

<i>Symptom</i>	<i>Try This...</i>
Cannot activate VOX	<p>VOX feature might be set to OFF.</p> <p>Use the CPS to ensure that the VOX Sensitivity level is not set to '0'.</p> <p>Accessory not working or not compatible.</p> <p>Refer to "Hands-Free Use/VOX" on page 27.</p>
Battery does not charge although it has been placed in the drop-in charger for a while	<p>Check drop-in tray charger is properly connected and correspond to a compatible power supply.</p> <p>Refer to "Charging with the Drop-in Tray Single Unit Charger (SUC)" on page 16 and "Charging A Stand-Alone Battery" on page 17.</p> <p>Check the charger's LEDs indicators to see if the battery has a problem. Refer to "Drop-in Tray Charger LED Indicators" on page 18.</p>

Note: Whenever a feature in the radio seems to not correspond to the default or preprogrammed values, check to see if the radio has been programmed using the CPS with a customized profile.

USE AND CARE



Use a soft damp cloth to
clean the exterior



Do not immerse in water



Do not use alcohol or
cleaning solutions

If the radio is submerged in water...



Turn radio OFF and
remove batteries



Dry with soft cloth



Do not use radio until
completely dry

FREQUENCY AND CODE CHARTS

The charts in this section provide Frequency and Code information. These charts are useful when using the Motorola XT Series two-way radios with other business radios. Most of the frequency positions are the same as the XTNi Series frequency positions.

Default Channel Frequency and Interference Eliminator Code

Channel #	Frequency (MHz)	Code	Bandwidth
1	446.00625	67.0 Hz	12.5 kHz
2	446.01875	67.0 Hz	12.5 kHz
3	446.03125	67.0 Hz	12.5 kHz
4	446.04375	67.0 Hz	12.5 kHz
5	446.05625	67.0 Hz	12.5 kHz
6	446.06875	67.0 Hz	12.5 kHz
7	446.08125	67.0 Hz	12.5 kHz
8	446.09375	67.0 Hz	12.5 kHz

Channel #	Frequency (MHz)	Code	Bandwidth
9	446.00625	754	12.5 kHz
10	446.01875	754	12.5 kHz
11	446.03125	754	12.5 kHz
12	446.04375	754	12.5 kHz
13	446.05625	754	12.5 kHz
14	446.06875	754	12.5 kHz
15	446.08125	754	12.5 kHz
16	446.09375	754	12.5 kHz

Note: Code 754 corresponds to DPL 121

CTCSS AND PL/DPL CODES

CTCSS Codes

CTCSS	Hz
1	67.0
2	71.9
3	74.4
4	77.0
5	79.7
6	82.5
7	85.4
8	88.5
9	91.5
10	94.8
11	97.4
12	100.0
13	103.5

CTCSS	Hz
14	107.2
15	110.9
16	114.8
17	118.8
18	123
19	127.3
20	131.8
21	136.5
22	141.3
23	146.2
24	151.4
25	156.7
26	162.2

CTCSS	Hz
27	167.9
28	173.8
29	179.9
30	186.2
31	192.8
32	203.5
33	210.7
34	218.1
35	225.7
36	233.6
37	241.8
38	250.3
122 (*)	69.3

Note: (*) New CTCSS code.

PL/DPL Codes

DPL	Code
39	23
40	25
41	26
42	31
43	32
44	43
45	47
46	51
47	54
48	65
49	71
50	72
51	73
52	74
53	114
54	115

DPL	Code
55	116
56	125
57	131
58	132
59	134
60	143
61	152
62	155
63	156
64	162
65	165
66	172
67	174
68	205
69	223
70	226

DPL	Code
71	243
72	244
73	245
74	251
75	261
76	263
77	265
78	271
79	306
80	311
81	315
82	331
83	343
84	346
85	351
86	364

d

DPL	Code
87	365
88	371
89	411
90	412
91	413
92	423
93	431
94	432
95	445
96	464
97	465
98	466
99	503
100	506
101	516
102	532
103	546

PL/DPL Codes (Continued)

DPL	Code
104	565
105	606
106	612
107	624
108	627
109	631
110	632
111	654
112	662
113	664
114	703
115	712
116	723
117	731
118	732
119	734
120	743

DPL	Code
121	754
123	645
124	Customized PL
125	Customized PL
126	Customized PL
127	Customized PL
128	Customized PL
129	Customized PL
130	Inverted DPL 39
131	Inverted DPL 40
132	Inverted DPL 41
133	Inverted DPL 42
134	Inverted DPL 43
135	Inverted DPL 44
136	Inverted DPL 45
137	Inverted DPL 46
138	Inverted DPL 47

PL/DPL Codes (Continued)

DPL	Code
139	Inverted DPL 48
140	Inverted DPL 49
141	Inverted DPL 50
142	Inverted DPL 51
143	Inverted DPL 52
144	Inverted DPL 53
145	Inverted DPL 54
146	Inverted DPL 55
147	Inverted DPL 56
148	Inverted DPL 57
149	Inverted DPL 58
150	Inverted DPL 59
151	Inverted DPL 60
152	Inverted DPL 61
153	Inverted DPL 62
154	Inverted DPL 63
155	Inverted DPL 64

DPL	Code
156	Inverted DPL 65
157	Inverted DPL 66
158	Inverted DPL 67
159	Inverted DPL 68
160	Inverted DPL 69
161	Inverted DPL 70
162	Inverted DPL 71
163	Inverted DPL 72
164	Inverted DPL 73
165	Inverted DPL 74
166	Inverted DPL 75
167	Inverted DPL 76
168	Inverted DPL 77
169	Inverted DPL 78
170	Inverted DPL 79
171	Inverted DPL 80
172	Inverted DPL 81

DPL	Code
173	Inverted DPL 82
174	Inverted DPL 83
175	Inverted DPL 84
176	Inverted DPL 85
177	Inverted DPL 86
178	Inverted DPL 87
179	Inverted DPL 88
180	Inverted DPL 89
181	Inverted DPL 90
182	Inverted DPL 91
183	Inverted DPL 92
184	Inverted DPL 93
185	Inverted DPL 94
186	Inverted DPL 95
187	Inverted DPL 96
188	Inverted DPL 97
189	Inverted DPL 98

PL/DPL Codes (Continued)

DPL	Code
190	Inverted DPL 99
191	Inverted DPL 100
192	Inverted DPL 101
193	Inverted DPL 102
194	Inverted DPL 103
195	Inverted DPL 104
196	Inverted DPL 105
197	Inverted DPL 106
198	Inverted DPL 107
199	Inverted DPL 108

DPL	Code
200	Inverted DPL 109
201	Inverted DPL 110
202	Inverted DPL 111
203	Inverted DPL 112
204	Inverted DPL 113
205	Inverted DPL 114
206	Inverted DPL 115
207	Inverted DPL 116
208	Inverted DPL 117
209	Inverted DPL 118

DPL	Code
210	Inverted DPL 119
211	Inverted DPL 120
212	Inverted DPL 121
213	Inverted DPL 123
214	Customized DPL
215	Customized DPL
216	Customized DPL
217	Customized DPL
218	Customized DPL
219	Customized DPL

MOTOROLA LIMITED WARRANTY

WARRANTY INFORMATION

The authorised Motorola dealer or retailer where you purchased your Motorola two-way radio and/or original accessories will honour a warranty claim and/or provide warranty service. Please return your radio to your dealer or retailer to claim your warranty service. Do not return your radio to Motorola. To be eligible to receive warranty service, you must present your receipt of purchase or a comparable substitute proof of purchase bearing the date of purchase. The two-way radio should also clearly display the serial number. The warranty will not apply if the type or serial numbers on the product have been altered, deleted, removed or made illegible.

WHAT IS NOT COVERED BY THE WARRANTY

- Defects or damage resulting from use of the Product in other than its normal and customary manner or by not following the instructions in this user guide.
- Defects or damage from misuse, accident or neglect.
- Defects of damage from improper testing, operation, maintenance, adjustment or any alteration or modification of any kind.
- Breakage or damage to aerials unless caused directly by defects in material or workmanship.
- Products disassembled or repaired in such a manner as to adversely affect performance or prevent adequate inspection and testing to verify any warranty claim.
- Defects or damage due to moisture, liquid or spills.
- All plastic surfaces and all other externally exposed parts that are scratched or damaged due to normal use.

- Products rented on a temporary basis.
- Periodic maintenance and repair or replacement of parts due to normal usage, wear and tear.

ACCESSORIES

AUDIO ACCESSORIES

Part No.	Description
00115	Remote Speaker Mic BR
00117	Headset w/Swivel Boom Mic
00118	Earbud w/Clip PTT Mic BR
00168	Lightweight headset

BATTERY

Part No.	Description
PMNN4434_R	Standard Li-Ion Battery
PMNN4453_R	High Capacity Li-Ion Battery

CABLES

Part No.	Description
HKKN4028_	Radio to Radio Cloning Cable
HKKN4027_	CPS Programming Cable

CHARGERS

Part No.	Description
PMLN6385_	Standard Drop-In Tray Single Unit Charger UK/EU Kit
PMLN6393_	Standard Drop-In Tray Multi-Unit Charger INT UK/EU

CARRY ACCESSORIES

Part No.	Description
HKLN4510_	Swivel Holster

Note: Certain accessories may or may not be available at the time of purchase. Please contact your Motorola Point of Purchase or visit www.motorolasolutions.com/XTSeries or www.motorolasolutions.com/radios/business for latest information on accessories availability and new accessories models.

Notes

MOTOROLA, MOTO, MOTOROLA SOLUTIONS and the Stylized M logo are trademarks or registered trademarks of Motorola Trademark Holdings, LLC and are used under license. All other trademarks are the property of their respective owners.

© 2013 Motorola Solutions, Inc.
All rights reserved.



MOTOROLA

Motorola Solutions, Inc.
1303 E. Algonquin Rd.
Schaumburg, IL 60196-1078, U.S.A.
<http://www.motorolasolutions.com>



68012009069-A

